



1002-1.23-19750XLR-SMC ELECTRIC THRUSTER



1002-1.23-19750XLR shown above.

All Innerspace thrusters are independently tested.

- No maintenance for 5 years or 5,000 hours other than oil changes.
- No disassembly required for fresh water rinsing.
- Streamlined Brushless DC, oil filled and pressure balanced motors.
- True direct drive electric motors. No gearbox, no magnetic coupling, nor any other device to transmit power, simplifying the design and increasing reliability.
- The venturi shape of the 1002-1.23 Series Thrusters are ideally suited for Electric Drive since the Propeller Turns Faster for the Same Power.
- Proven 3 tier seal system that includes Silicone Carbide Face Shaft Seals.
- 90% Reverse Thrust
- High Efficiency and Much Faster Response Time. Thrusters that will make a difference to any ROV's / Submarines performance
- All USA made materials, manufacturing and assembly.
- Independently Tested Off-The-Shelf Units that have a proven track record.

PRECISION DESIGNED AND BUILT - COMPARE EFFICIENCIES & PROP TIP CLEARANCES.

Customized Solutions/Systems for R & D Programs or Prototype Vehicles, small or large. These thrusters can be precision matched to each application.



PERFORMANCE DATA & THRUSTER DIMENSIONS

1002-1.23-19750XLR-SMC Motor Specifications				
Input Voltage	Max Thrust	RPM	Input Power	Shaft Power
750 VDC	1201 lbf (545 kgf)	2,500	58.8 HP (43.9 kW)	54.8 HP (40.9 kW)
Reverse Thrust				
750 VDC	1088 lbf (494 kgf)	2,500	58.8 HP (43.9 kW)	54.8 HP (40.9 kW)

1002-1.23 Electric Thruster with 19750XLR Motor Performance Table

Speed (RPM)	System Voltage (VDC)	Min Voltage (VDC)	Current (A rms)	Torque		Bollard Thrust		Reverse Thrust		Power Shaft		Power In		Efficiency (Pout/Pin)
				(N-M)	(In-Lbs)	0 (Lbf)	0 (Kgf)	(Lbf)	(Kgf)	(HP)	(Watts)	(Watts)	(HP)	
100	750	24.3	0.5	1.2	10.2	2	0.9	2	0.8	0.02	12	12	0.0	98.7%
200	750	48.5	0.8	1.9	16.8	8	3.5	7	3.2	0.05	40	40	0.1	98.9%
400	750	97.5	2.2	4.9	43.2	31	13.9	28	12.6	0.27	204	207	0.3	98.6%
600	750	147.2	4.4	9.8	87.2	69	31.4	63	28.4	0.83	619	631	0.8	98.1%
800	750	197.6	7.5	16.8	148.7	123	55.8	111	50.5	1.89	1408	1443	1.9	97.6%
1000	750	248.8	11.5	25.7	227.9	192	87.1	174	79.0	3.62	2697	2778	3.7	97.1%
1200	750	300.8	16.4	36.7	324.6	277	125.5	251	113.7	6.18	4611	4774	6.4	96.6%
1500	750	380.2	25.4	56.8	502.7	432	196.1	392	177.7	11.97	8926	9317	12.5	95.8%
1800	750	461.3	36.4	81.4	720.4	622	282.4	564	255.9	20.58	15349	16152	21.7	95.0%
2000	750	516.4	44.8	100.3	887.5	769	348.6	696	315.9	28.16	21011	22229	29.8	94.5%
2200	750	572.2	54.2	121.2	1072.2	930	421.8	843	382.2	37.43	27921	29700	39.8	94.0%
2300	750	600.3	59.2	132.3	1171.2	1016	461.0	921	417.8	42.74	31884	34006	45.6	93.8%
2400	750	628.7	64.4	144.0	1274.5	1107	502.0	1003	454.9	48.53	36206	38719	51.9	93.5%
2450	750	643.0	67.1	150.0	1327.8	1153	523.1	1045	474.1	51.62	38507	41234	55.3	93.4%
2500	750	657.3	69.8	156.2	1382.2	1201	544.7	1088	493.6	54.83	40903	43859	58.8	93.3%

Table Information:

- 1) The Minimum Voltage column in the above table shows the minimum Voltage needed to achieve the performance at that corresponding propeller RPM/Thrust.
- 2) The Current shown represents the continues RMS Current to the motor to achieve the Thrust at the corresponding propeller RPM.
- 3) The Shaft HP developed is a function of the propeller and increases with propeller RPM.
- 4) The maximum performance achieved will depend on the limitations of customers system Voltage and driver Current capacity.
- 5) For Thrust at Forward Vehicle Speed (Kts), anything lower than 500 RPM varies greatly with vehicle design.
- 6) The Current/RPM might need to be limited depending on customer connector spec and or system Current limitations.
- 7) Minimum Voltage to achieve full Thrust is 657 VDC.
- 8) Max Voltage should not exceed 10% of rated Voltage.



1002-1.23-19750XLR Dimensions

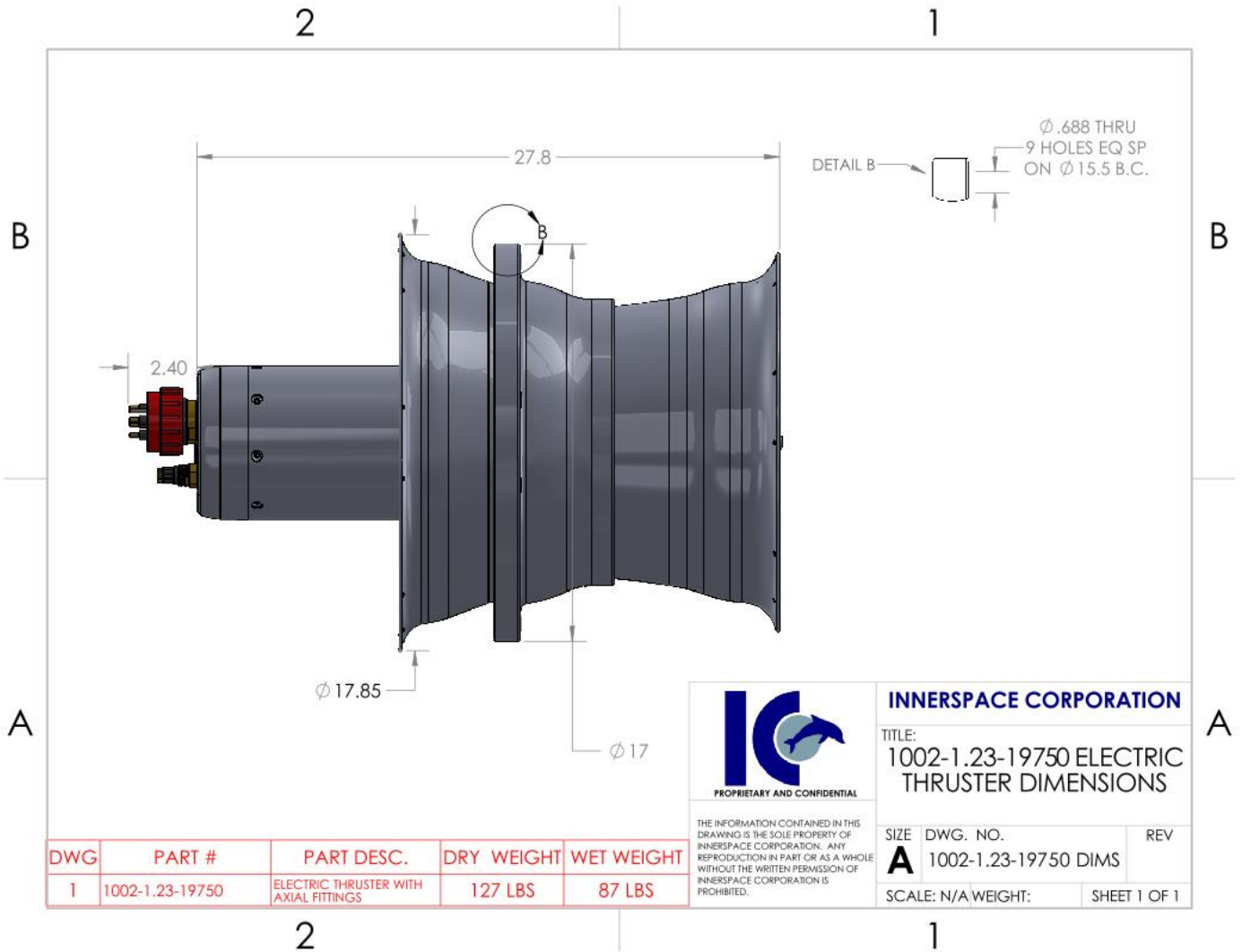

The Electric Thrusters can be ordered with almost any customer preferred connectors if Current ratings are taken into consideration.
 The above Drawing shows the 1002-1.23-19750XLR Thruster Dimensions with Vertical Fittings/Bulkheads (1) and Axial fittings/Bulkheads (2).



GENERAL ARRANGEMENT

19750XLR BDC MOTOR
DIRECT DRIVE – Propeller Attached on the same shaft
that the Magnets are on without any other device to
transmit power to the Propeller.

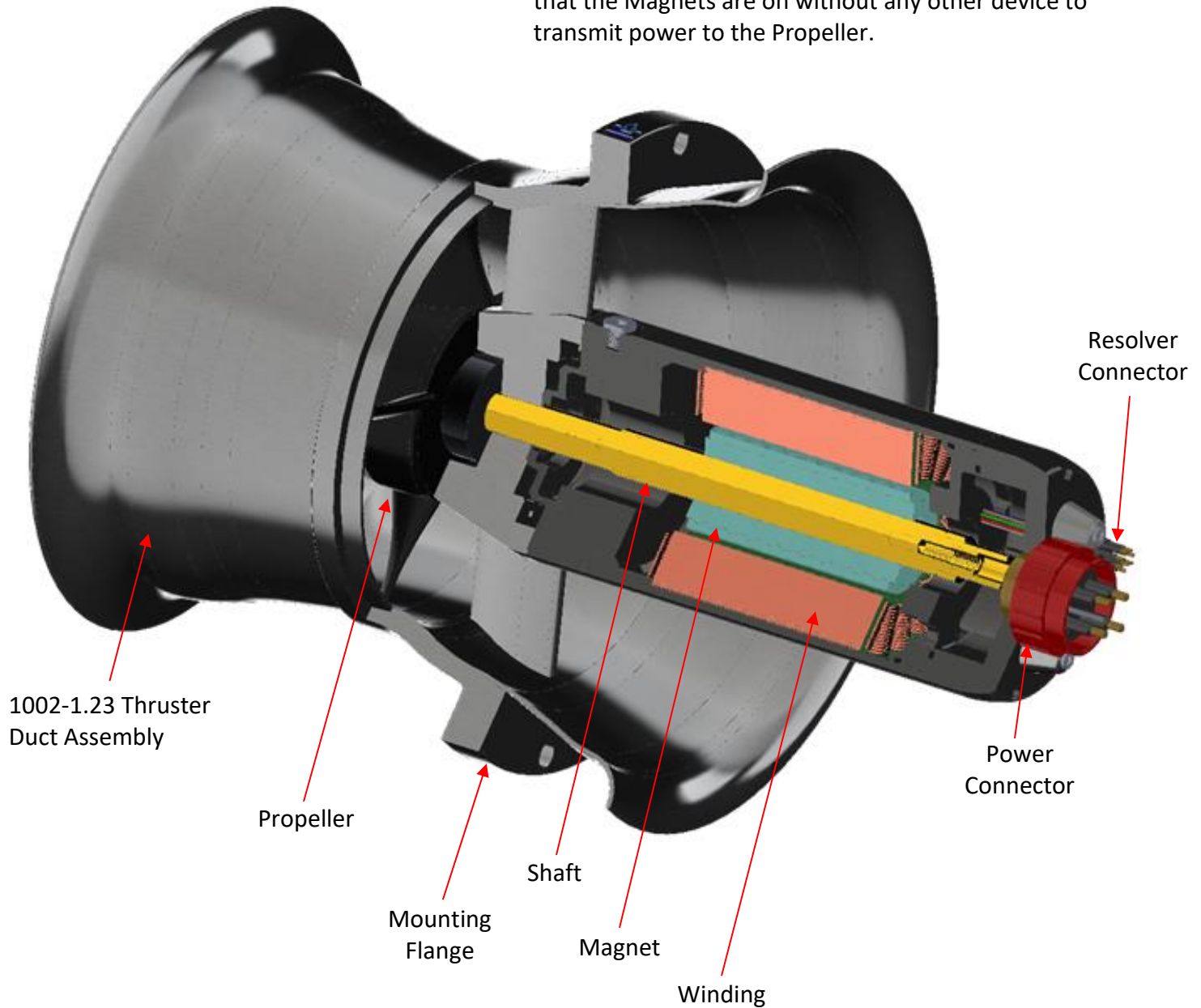



STATE-OF-THE-ART AMBIENT PRESSURE MOTOR CONTROLLER FROM 50 – 780 VDC

The 1002-1.23 Series Electric Thrusters are offered with a matching SMC (Stand-alone Motor Controller) housed in a separate one atmosphere bottle. Specially designed to match the 1002-1.23 Series Electric Thruster range from Innerspace, the SMC controller operates in torque or velocity mode. Torque mode is particularly useful when integration to a vehicle stability control system is anticipated, allowing percentage torque thrust forward and reverse to the RPM limit of the motor. Feedback from the motor to the system controller receipt of the digital commands sent and provides real time RPM and motor Current, along with system health and performance monitoring data. Motor acceleration rates and other parameters can be set to suit the motor and application.

Recording of lifetime performance data including total shaft revolutions, hours since overhaul and power cycles provide data points for operation and maintenance purposes are standard.



Stand-alone Motor Controller (SMC)
Sizes will vary depending on depth.



INNERSPACE CORPORATION

1138 E. EDNA PLACE, COVINA, CA 91724

TEL: (626) 331-0921 FAX: (626) 966-6391

www.innerspacethrusters.com

SPECIFICATIONS

SMC (Stand-alone Motor Controller):

Type:

Atmospheric Pressure Housed Three Phase BLDC motor controller.

Available Configurations:

Stand Alone (SMC): Independent control unit with cable connections to motor - phase (power) and sensing (resolver) Communication (Network).

Motor Power Rating: 1hp (750W) to 25hp (18kW) with options to 55hp (41kW)

General Characteristics:

Voltage: DC, 50VDC to 780VDC, Positive, Negative, Isolated from Frame Ground.

Current: Maximum Continuous 50A (in water)

Motor Type: Suitable for Three Phase water cooled BLDC Permanent Magnet motors

Operating Parameters: Stand Alone Controller: Sine/CoSine resolver and direct commutation
Controller parameter matched to associated motor.

Connections

Power: Subconn HPBH4M - Positive, Negative and Frame Safety Ground

Data: SubConn DBH13M – 1. 24V+, 2. SHD, 3. 0V-, 4-7 RESERVED, 8. ECAT TX+, 9. ECAT TX-, 10. ECAT RX+, 11. ECAT RX-, 12 & 13 RESERVED

Motor Phase: Subconn HPBH4F - Phase A, B, C, Frame Ground/Shield

Motor Sensor: Subconn DBH8F Sensor SIN+/-, COS+/-, EXC+/- Frame Ground/Shield

Control

Electrical: Ethercat point to point connection.

A separate 24VDC LV supply used with the Ethercat connection. This enables the condition of the controller to be known without the HV being present. Communication of all the motor parameters is possible.

Command: Over 300 commands available please contact for requirements

Ethercat SDO and PDO:

Action Commands: RPM setting (velocity mode) - Forward and Reverse, to rated motor RPM

Power setting (torque mode)- Forward and Reverse, 0% to 100% of maximum rated/programmed torque

Safety Lockout (Manual)

Status query

Status Messages: Shaft RPM

Motor Current

Throttle/Thrust setting

Temperature

Safety State Action: Condition warnings (Temperature, Voltage, Current)

Control System Connectivity Failure - Automatic shutdown

Notes:

- Optional External Control Interfaces: Test interface and development code
- DC supply cables must meet minimum length/inductance requirements to eliminate requirement for an external HVDC soft start switch.
- Adequate DC bus capacitance and reverse EMF/Overvoltage protection must be used.
- All Data cable must be shielded for noise prevention
- Data cable should not exceed 6 meters between SMC and electric motors.