



1002 & 1002H SERIES ELECTRIC THRUSTER WITH 14300 MOTOR



- Streamlined Brushless DC, oil filled and pressure balanced motors.
- The direct drive electric motors simplifying the design and increasing reliability.
- Integrated (Inside the motor) or stand-alone controller that is oil filled and pressure balanced, eliminating the need for a motor controller housed in a separate one atmosphere bottle.
- The venturi shape of the 1002 Thruster is ideally suited for Electric Drive since the Prop Turns Faster for the Same Power.
- Proven 3 tier seal system that includes Silicone Carbide Face Shaft Seals.
- 90% Reverse Thrust
- High Efficiency and Much Faster Response Time. Thrusters that will make a difference to your ROV's / Submarines performance
- All USA made materials, manufacturing and assembly.
- Independently Tested Off-The-Shelf Units that have a proven track record.

PRECISION DESIGNED AND BUILT - COMPARE EFFICIENCIES & PROP TIP CLEARANCES.

- Optional Hexscreens of Hydrodynamic Design Protects Divers & the Prop.
- Cancels 80% of the Prop Torque While Reclaiming Thrust by Reducing Jet Whirl. Steadier Vehicle.

Customized Solutions/Systems for R & D Programs or Prototype Vehicles, small or large. These thrusters can be precision matched to each application.



STATE-OF-THE-ART AMBIENT PRESSURE MOTOR CONTROLS FROM 100-550VDC

The 1002 series electric thrusters are offered with a matching integrated or stand-alone controller option, oil filled and pressure balanced, eliminating the need for a motor controller housed in a separate one atmosphere bottle.

Where space allows the Integrated Motor Controller (IMC) option is a two-connection solution to the thruster. The separate HV DC power feed and low voltage digital control connection provide a simple interconnect to vehicle systems, and very low radiated emissions.

Where space does not allow, the Stand-alone Motor Controller (SMC) is offered in a separate bottle with resolver and phase power connections to the motor.

Specially designed to match the 1002 Series Electric Thruster range from Innerspace, the IMC integrated controller operates in torque or velocity mode. Torque mode is particularly useful when integration to a vehicle stability control system is anticipated, allowing percentage torque thrust forward and reverse to the RPM limit of the motor. Feedback from the motor to the system controller receipt of the digital commands sent and provides real time RPM and motor current, along with system health and performance monitoring data. Motor acceleration rates and other parameters can be set to suit the motor and application.

Recording of lifetime performance data including total shaft revolutions, hours since overhaul and power cycles provide data points for operation and maintenance purposes are standard.

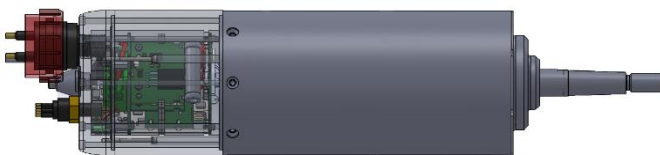

Integrated Controller (IMC)
Mounts on rear of motor body

Stand-alone Motor Controller (SMC)
Bottle w/o connectors $\varnothing 4.72'' \times 5.86''$



SPECIFICATIONS IMC (Integrated Motor Controller) or SMC (Stand-alone Motor Controller):

Type: Oil filled, Pressure Balanced Three Phase BLDC motor controller.

Available Configurations:

Integrated (IMC): Directly attached to motor - includes all control elements within motor housing.

Stand Alone (SMC): Independent control unit with cable connections to motor - phase (power) and sensing (resolver).

Motor Power Rating: Integrated: 1hp (750W) to 25hp (18kW)
Stand Alone: 1hp (750W) to 25hp (18kW) with options to 55hp (41kW)

General Characteristics:

Voltage: DC, 100VDC to 550VDC, Positive, Negative, Isolated from Frame Ground.

Current: Maximum Continuous 50A (in water - limited by connector capability)

Motor Type: Suitable for Three Phase water cooled BLDC Permanent Magnet motors

Integrated Controller: End effect magnetic shaft position sensor and direct commutation

Stand Alone Controller: Sine/CoSine resolver and direct commutation

Operating Parameters: Controller parameter matched to associated motor.

Connections - Integrated Option

Power: Three Pin Rated for Applicable Current - Positive, Negative and Frame Safety Ground

Data: Five Pin (e.g. SubConn Micro Circular) - +12V, 0V, CAN+, CAN-, Frame Safety Ground

Connections - Stand Alone Option

Power: Three Pin Rated for Applicable Current - Positive, Negative and Frame Safety Ground

Data: Five Pin (e.g. SubConn Micro Circular) - +12V, 0V, CAN+, CAN-, Frame Safety Ground

Motor Phase: Phase A, B, C, Frame Ground/Shield

Motor Sensor: Sensor SIN+/-, COS+/-, EXC+/- Frame Ground/Shield

Control

Electrical: CAN bus point to point electrical connection.

A separate 12VDC LV supply used with the CAN bus allows independent powering of the control electronics. This enables the condition of the controller (and for the IMC the controller/motor) to be known without the HV being present. Communication of all of the motor parameters is possible, and RPM is also reported.

Command: MOD bus command set with defined command set including:

Query Commands, Action Commands and Maintenance Commands.

Command

Action Commands: RPM setting (velocity mode) - Forward and Reverse, to rated motor RPM
Power setting (torque mode)- Forward and Reverse, 0% to 100% of maximum rated/programmed torque
Safety Lockout (Manual)

Status Messages: Status query
Shaft RPM
Motor Current
Throttle/Thrust setting
Temperature

Safety State Action: Condition warnings (temperature, voltage, current)
Control System Connectivity Failure - Automatic shutdown

Notes:

- Optional External Control Interfaces: Test interface and development example code (for use in development)
- For safety and security purposes, the CAN communications bus is point to point, not multi-drop.
- DC supply cables must meet minimum length/inductance requirements to eliminate requirement for an external HVDC soft start switch.
- Adequate DC bus capacitance and reverse EMF/Overtorque protection must be used.



PERFORMANCE DATA & THRUSTER DIMENSIONS

1002H with 14300 Motor Specifications.				
INPUT VOLTAGE	Max Thrust	RPM	Input Power	Shaft Power
300 VDC MAX	419 lbf (190 kgf)	2,300	12.8 HP (9.5 kW)	12.07 HP (9 kW)
Reverse Thrust				
300 VDC MAX	375 lbf (170 kgf)	2,300	12.8 HP (9.5 kW)	12.07 HP (9 kW)

1002H Hexscreen Electric Thruster with 14300 Motor Performance Table

SPEED	VOLTAGE	CURRENT	THRUST (Lbf) at Bollard Condition (0 kts) to 6 kts vehicle speed							REVERSE Thrust (lbf)	POWER SHAFT (HP)	POWER IN (HP)	Efficiency
			0 kts	1 kts	2 kts	3 kts	4 kts	5 kts	6 kts				
RPM	(VDC)	(A rms)											Pout/Pin
100	100.0	1.0	1	-	-	-	-	-	-	1	0.02	0.0	96.4%
200	100.0	1.2	4	-	-	-	-	-	-	3	0.04	0.0	97.7%
300	100.0	1.4	6	-	-	-	-	-	-	5	0.06	0.1	97.9%
400	100.0	2.0	15	14	14	13	12	11	11	13	0.14	0.1	97.9%
500	100.0	2.7	24	23	22	21	20	19	17	21	0.24	0.2	97.9%
600	100.0	3.5	35	32	30	28	26	25	24	30	0.37	0.4	97.7%
800	100.0	5.5	61	58	56	53	51	48	46	54	0.78	0.8	97.4%
1000	116.2	8.0	95	91	87	83	79	75	72	86	1.43	1.5	96.9%
1100	128.3	9.5	115	110	105	100	96	91	87	105	1.86	1.9	96.7%
1200	140.6	11.2	137	131	125	119	114	109	104	124	2.38	2.5	96.5%
1300	152.9	13.0	160	153	146	139	133	127	121	143	2.99	3.1	96.2%
1400	165.3	14.9	186	178	170	162	154	147	141	168	3.70	3.9	96.0%
1500	177.9	17.0	213	203	194	185	177	169	161	192	4.51	4.7	95.8%
1600	190.5	19.2	243	232	221	211	202	193	184	220	5.44	5.7	95.5%
1700	203.3	21.5	274	262	250	238	228	217	207	246	6.49	6.8	95.3%
1800	216.2	24.0	307	293	280	267	255	243	232	278	7.68	8.1	95.0%
1900	229.1	26.7	342	326	312	298	284	271	259	309	8.99	9.5	94.8%
2000	242.2	29.4	380	362	345	330	315	301	287	342	10.45	11.1	94.5%
2100	255.4	32.4	419	399	381	364	347	331	316	375	12.07	12.8	94.3%

Table Information:

- 1) Voltage in the above chart shows the minimum voltage needed to achieve the performance at that given propeller rpm
- 2) The system voltage should typically be 20-40 VDC higher than the minimum voltage referenced above.
- 3) The Current shown represents the continues RMS current to the motor to achieve the torque at the corresponding propeller rpm.
- 4) The Shaft HP developed is a function of the propeller and increases with propeller rpm.



- 5) The maximum performance achieved will depend on the limitations of customers system voltage and driver current capacity.
- 6) For Thrust at Forward Vehicle Speed (kts), anything lower than 500 rpm varies greatly with vehicle design.
- 7) Thrust at forward vehicle speed from 1 kts to 6 kts is based on a local water speed with a very conservative vehicle wake factor. Basically, estimated conservatively at worst case from test results of various customer vehicles
- 8) The current/rpm might need to be limited depending on customer connector spec and or system current limitations.

1002H Dimensions with different configurations.

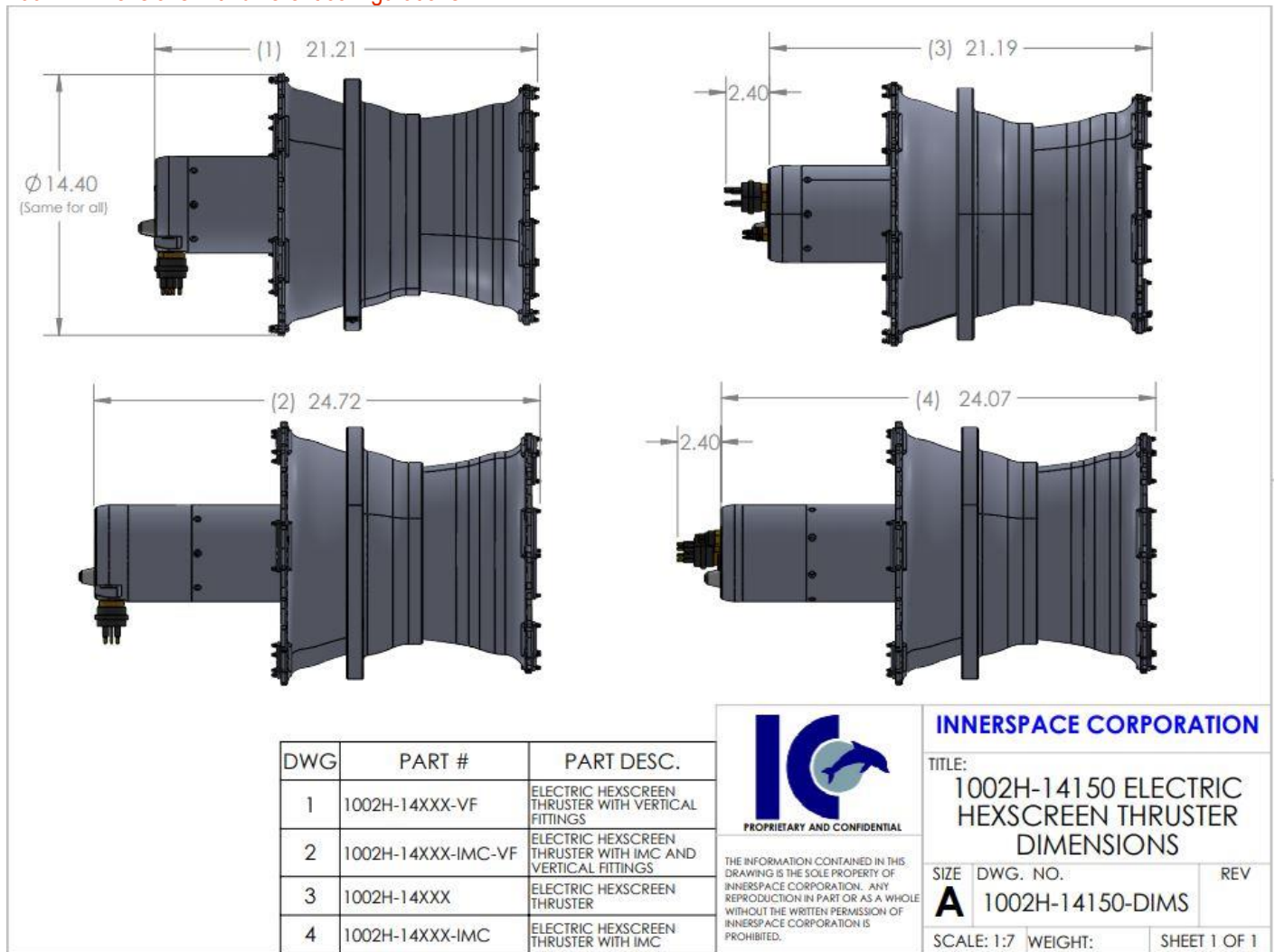

The Electric Thrusters can be ordered with almost any customer preferred connectors if current ratings are taken into consideration.

The above Drawing shows the 1002H Thruster Dimensions with and without the IMC (Integrated Motor Controller) and with two different connector orientations. The SMC(Stand-alone Motor Controller is shown in the below General Arrangement Diagram.



GENERAL ARRANGEMENT

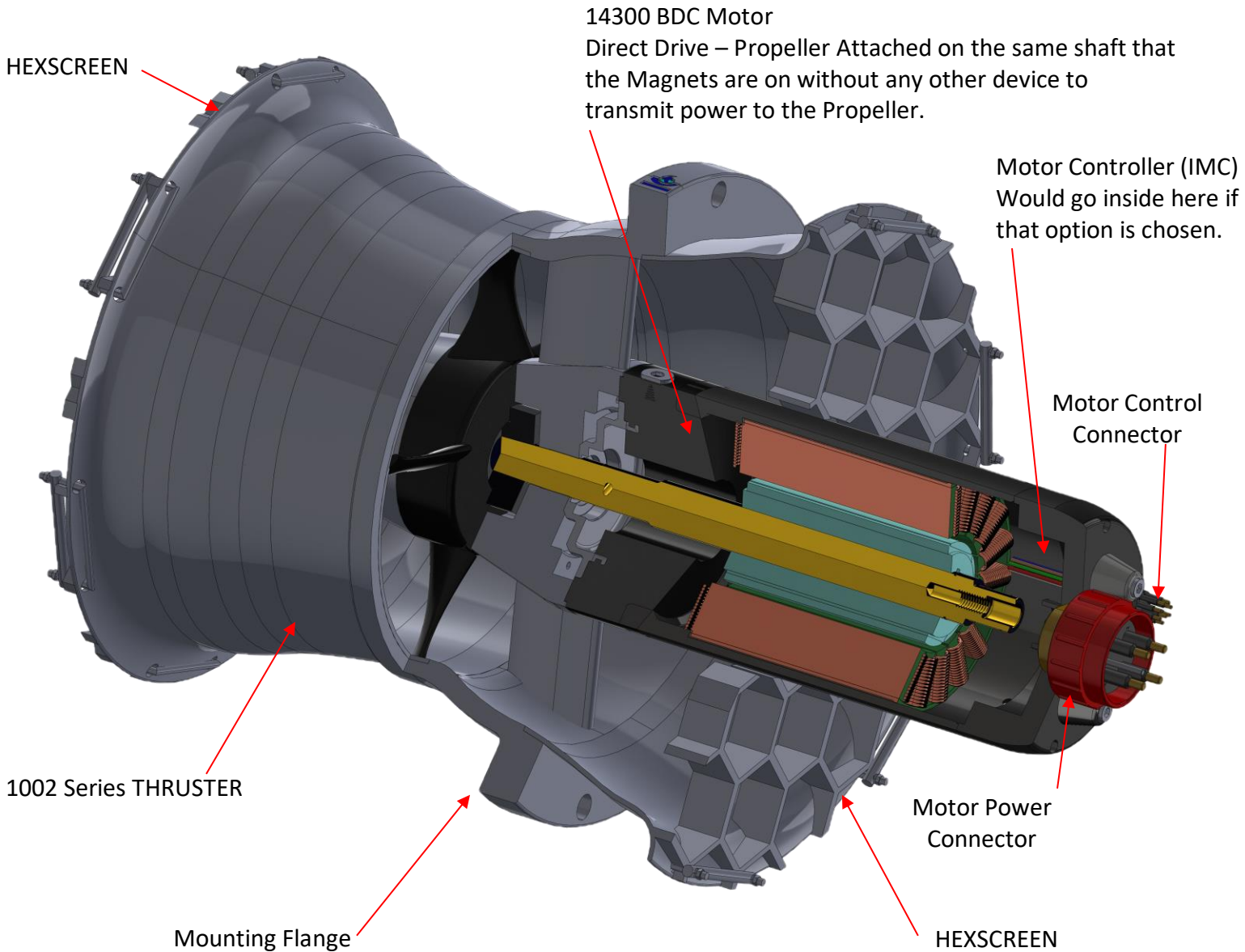

Stand-alone Motor controller option that is not mounted on the back of the motor. Electronics are inside a separate oil filled housing that is connected to the back of the motor via a power cable and feedback cable.

